

**PACO**  
PUMPS

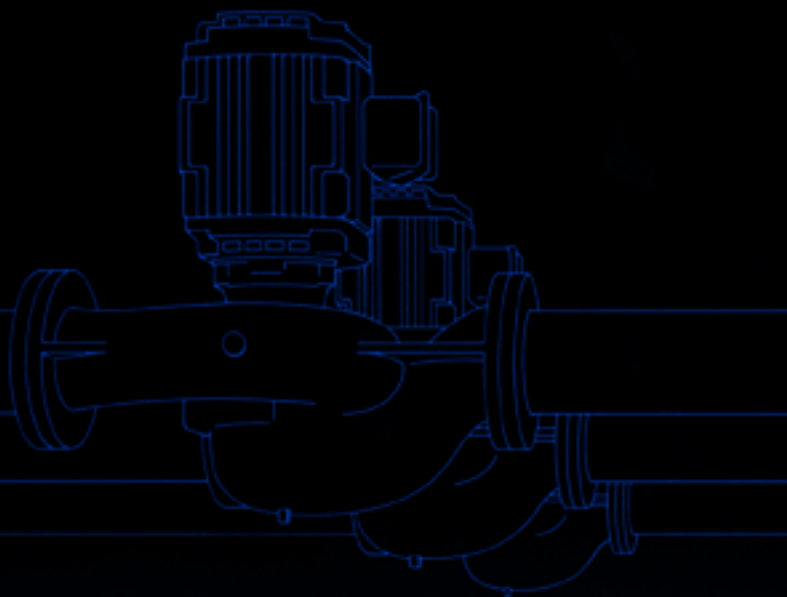

**Paco Type VL  
Vertical In-Line  
Centrifugal Pumps**

## **Paco Pumps Quality and Service for Over 90 Years**

PACO Pumps represents quality and service with over 90 years of experience in the design, manufacture and application of centrifugal pumps and pumping systems.

PACO's commitment to state-of-the-art pump design has brought the Type VL Verticle In-Line pumps into the SMART Pump family of products.

Worldwide installations have proven the versatility of PACO's Type VL Verticle In-Line pumps, which meet and/or exceed the requirements of a variety of market applications, including chilled water, condenser water and hot water systems.

PACO Type VL Verticle In-Line pumps are available with Suction and Discharge flanges from 1 1/4" through 10", developing flows to 3600 gpm and heads to 400 feet. The Type VL Verticle In-Line pumps are available in a variety of metallurgies and mechanical configurations (both 175-lb. and 250-lb. working pressures.)

Pump cost is not the only factor when considering pump economy. The cost of installation, maintenance, power, service and spare parts account for more than 90% of the total cost throughout the life of the pump. Cost-effective pumping is PACO's commitment to quality and service to our customers.



ESTABLISHED 1907 ✦ SAN FRANCISCO, CALIFORNIA

# Paco Type VL Features and Operating Advantages

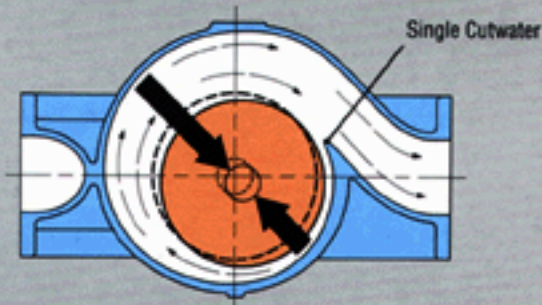

**Fig. 1—Single volute design.** The normal single volute design has high unbalanced radial thrust on shaft and impeller, causing shaft deflection and premature wear of seals, bearings, wear rings, and impeller.

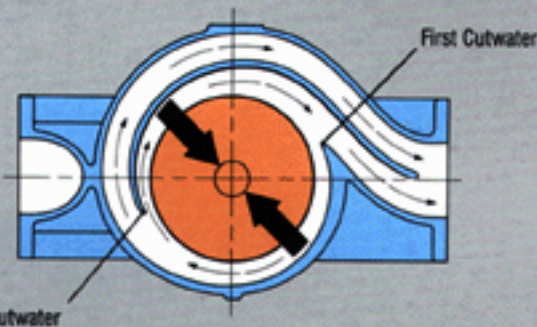

**Fig. 2—Double volute design.** The PACO Type VL double volute design is superior due to opposing offsetting radial thrust forces on the shaft and impeller, resulting in much lower radial loads, longer life, lower maintenance, and quieter operation. Double volute is standard on 3" and larger pumps.

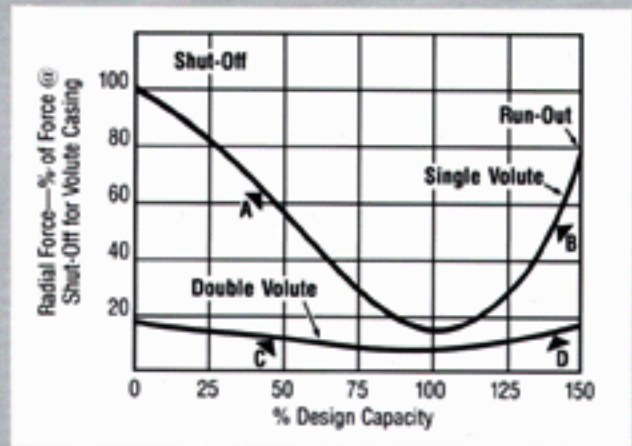

**Fig. 3—Typical comparison of radial force vs. design capacity with single and double volute.**

A pump is normally designed to operate at 100% capacity head, or within a narrow range of this point, which results in minimal radial thrust. However, in actual operation, the pumping condition will frequently change either toward "shut-off" or "run-out" condition, due to a load variance or miscalculation of the system head curve. The resulting radial thrust on an impeller encased in a **single volute** under these condition can be of sufficient magnitude to cause premature wear and shaft failure, especially since the force is cyclic in nature, due to rotation. See Points A and B, Fig. 3.

The basic principle of a double volute is to divide the flow into similar geometric regions with two cutwaters 180° apart (see Fig. 2). Although the volute pressure inequities remain as in a single volute casing, there are two resultant impeller radial forces opposing each other which contain the shaft in a normal axis of rotation. The net radial force is at a low level throughout the range of capacity of the pump. See Points C and D, Fig. 3.

## Paco Type VL Quieter Operation and Higher Efficiency

**Prolonged pump efficiency.** Replaceable wear rings, a standard PACO feature, allows owner to maintain pump efficiency at a low cost.

**Large capacity range and sizes.** Capacities to 3600 gpm, heads to 400 feet, sizes: 1/4" to 10" discharge.



15 Floor Mounted Type VL In-Line Pumps supplying chilled and condensed water.—A major high-rise hotel at Baltimore's Inner Harbor

**High working pressure applications.** PACO's full line of Type VL Vertical In-Line pumps are available with 250-lb. rated flanges for case working pressures to 250 psi. (Sizes from 1/4" to 10" suction/discharge.)

PACO also has 300 psi working pressure In-Lines with balanced seals. Sizes ranging from 1/4" to 2", horsepowers from 3 through 15, flows to 175 gpm and heads to 225'.

The 300 psi In-Lines (see Sales Brochure A3-2a) are ideally suited for high pressure packaged water cooled air conditioning units—for computer room additions, increased tenant population, tenant changes requiring increased air conditioning loads. Whatever the need, PACO Pumps' In-Lines can fill the requirement.

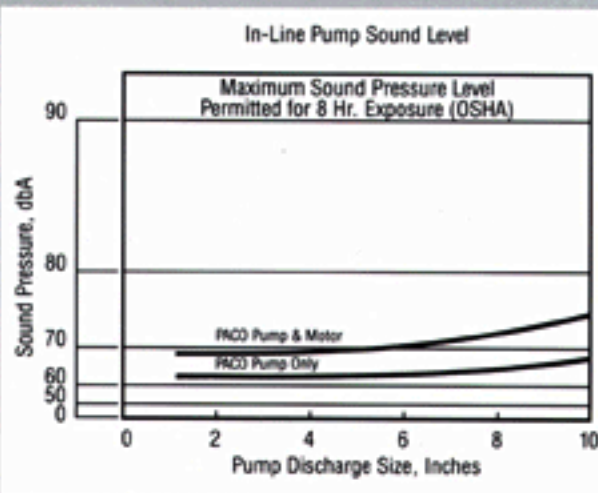

**Minimum pump noise.** . . . a necessity in most applications. Construction costs for modern commercial and industrial buildings have led to closer proximity of work areas to mechanical rooms. Because fluid- or structure-borne noise problems are difficult and costly to solve, quiet running equipment has become essential in nearly every application.

To ensure pump owners of the least possible noise problems, maximum sound levels should clearly be specified in the same manner as capacity, head and efficiency requirements. Data reflected by the chart derives from sound level requirements and test procedures performed in accordance with Hydraulic Institute's standards for measuring sound produced by conventional pumping equipment.

The Type VL Vertical In-Line Pump, now in the Smart Pump family of products, has superior hydraulic and mechanical design that produces higher efficiency, reliability, and reduced pump noise. The impeller vane outlet design, for example, avoids pulsations at the fluid exit. Features such as the compensated double volute, dynamically balanced impellers, and short shaft help keep vibration to a minimum.

# Paco Type VL Vertical In-Line Performance Ranges

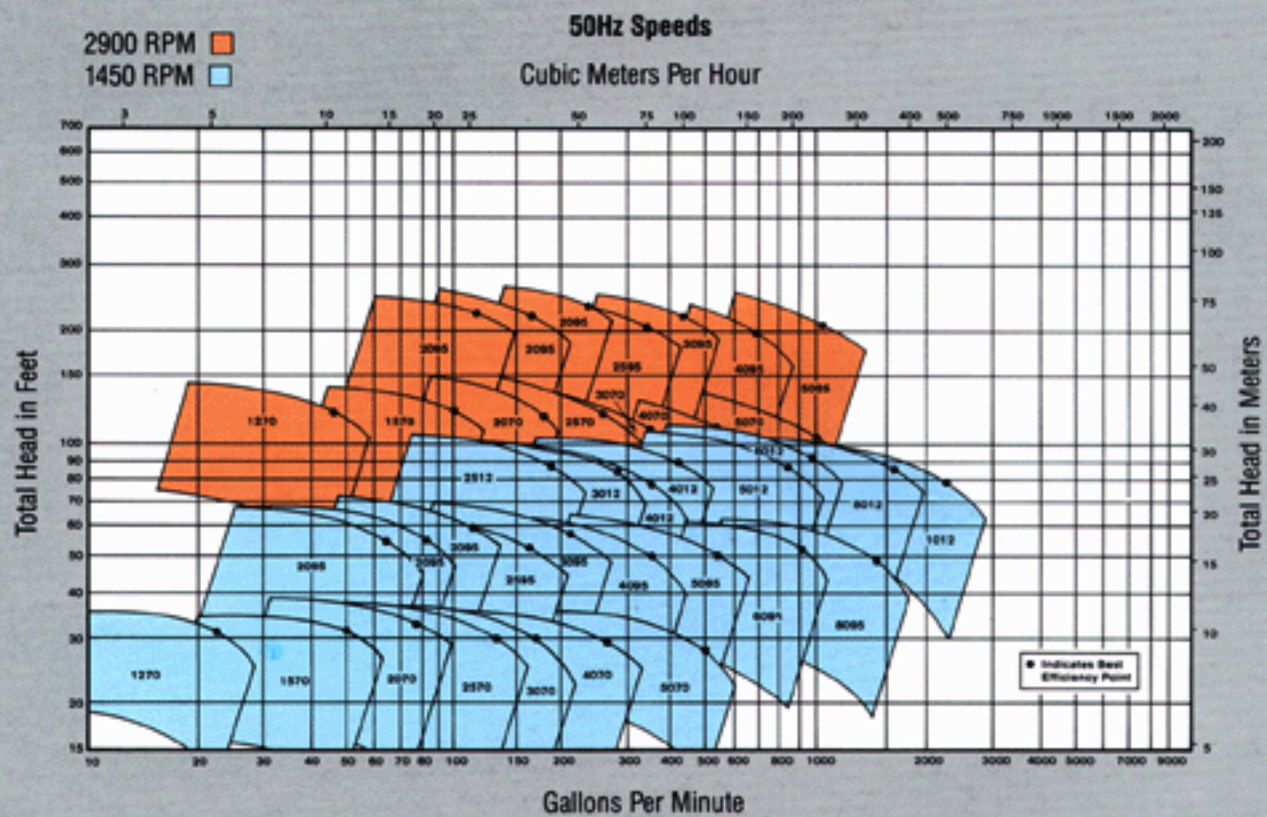
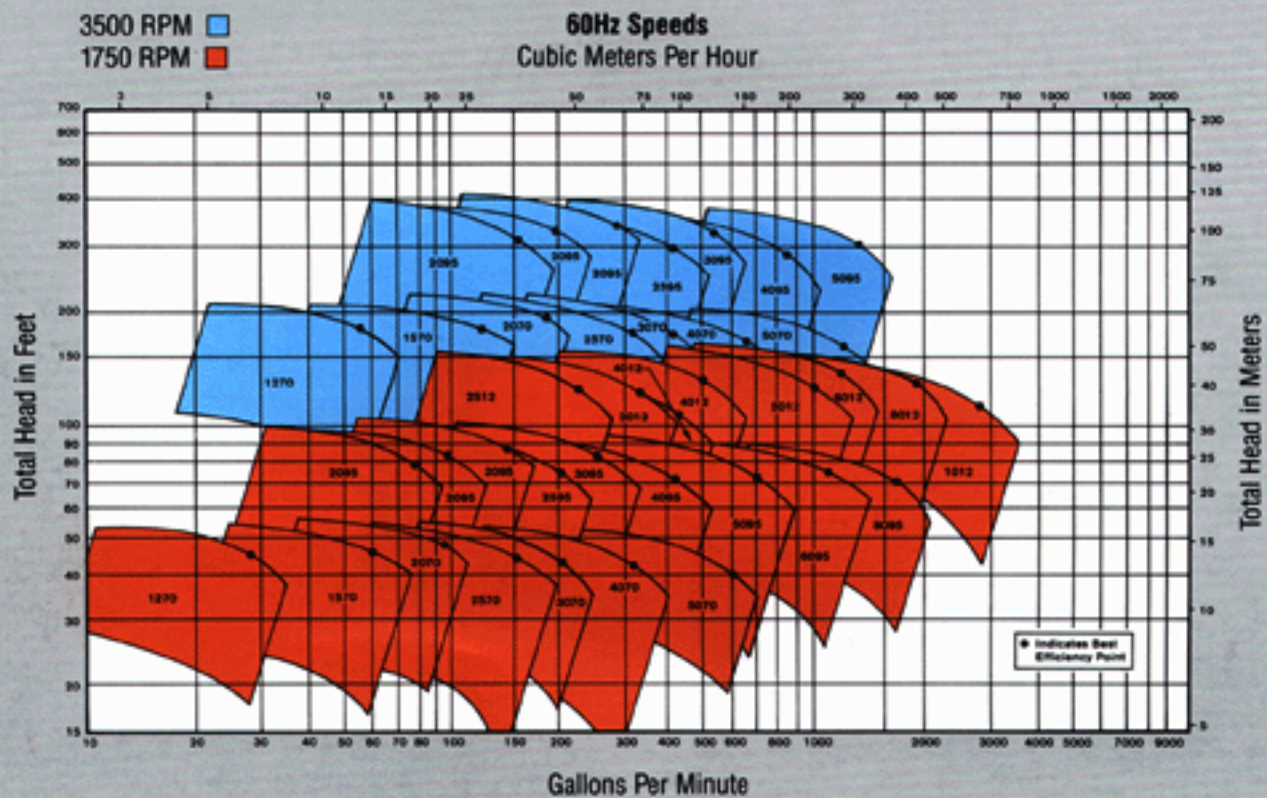

## Paco Type VL Installation Advantages and Options

Saves Floor Space

No Flexible Connectors

No Foundation Grouting

Reduces Piping

Mounts Like a Valve for Quick Installation

No Coupling Alignment

No Bearing Frame Assembly

Easier to Maintain

Smaller Spare Parts Inventory

Equal Size Suction and Discharge Pipes

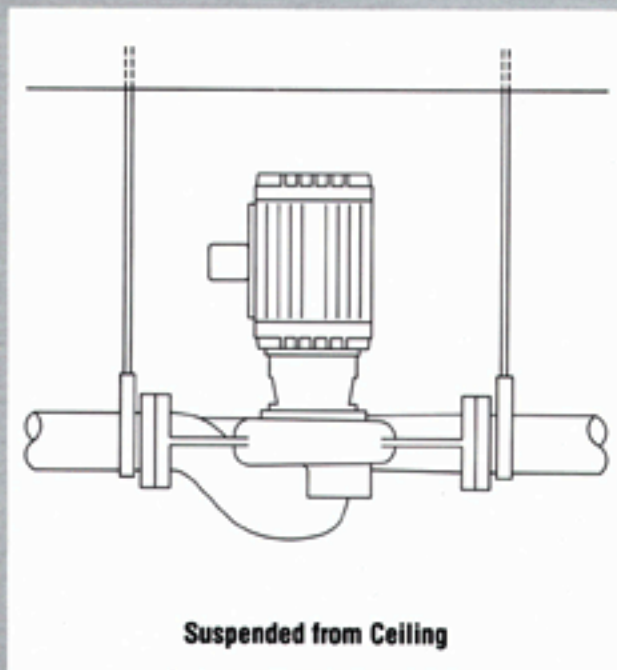

### Floor Mounted

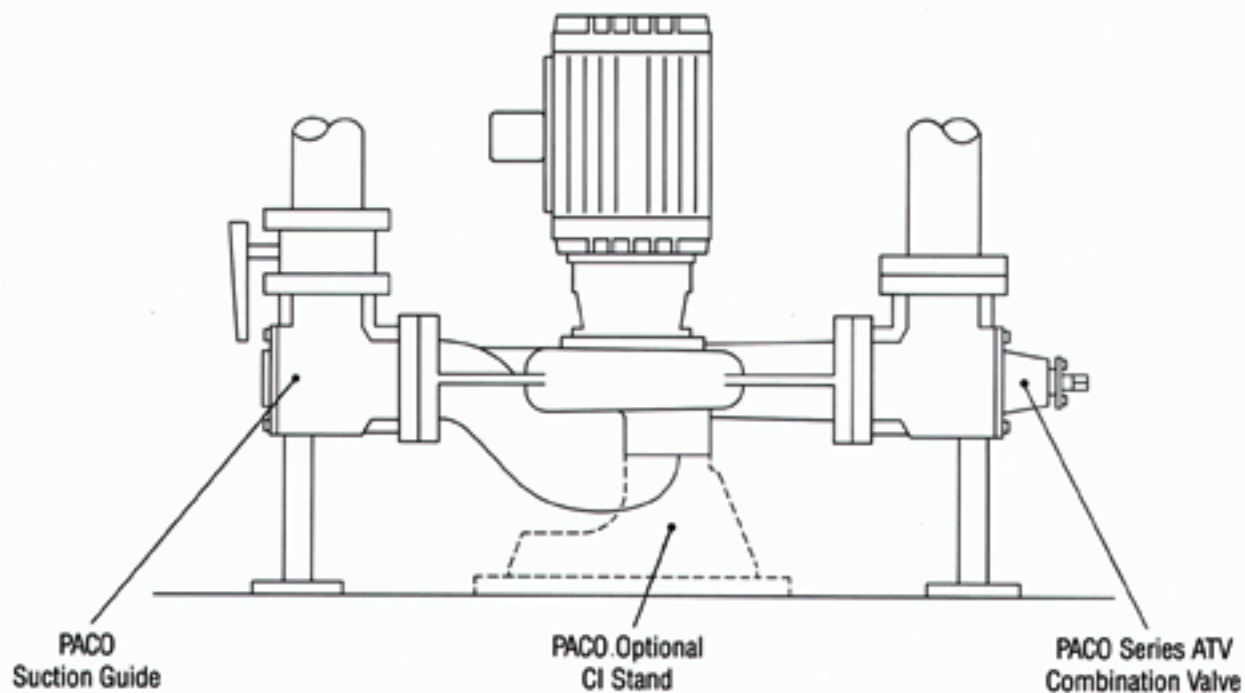

## Paco Sales and Service Centers and Regional Offices

### Central Regional Sales Office

902 14th Street  
Silvis, IL 61282  
(309)792-9900  
Fax: (309)792-8621

### Dallas

4677 Mint Way  
Dallas, TX 75236  
(214)339-3156  
Fax: (214)330-4482

### Pomona

3215 Producer Way  
Pomona, CA 91768  
(909)594-9959  
Fax: (909)594-1335

### East Regional Sales Office

2 Bourbon Street  
Peabody, MA 01960  
(978)535-8000  
Fax: (978)535-8142

### Oakland

845 92nd Avenue  
Oakland, CA 94603  
(510)639-3200  
Fax: (510)639-3337

### Portland

2551 N.W. 30th  
Portland, OR 97210  
(503)224-6330  
Fax: (503)241-0399

### Sacramento

1331 "T" Street, Suite 20  
Sacramento, CA 95814  
(916)443-2412  
Fax: (916)443-1145

### San Diego

9245 Dowdy Drive, Suite 207  
San Diego, CA 92126  
(619)536-7999  
Fax: (619)536-9595

### Seattle

3215 South 116th Street  
Seattle, WA 98168  
(206)433-2600  
Fax: (206)433-0263

### West/Southwest Regional Sales Office

800 Koomey Road  
Brookshire, TX 77423  
(281)934-6279  
Fax: (281)934-6082

### Pacific Rim

Pasir Panjang Distripark Blok. 1#02-20  
Pasir Panjang Road  
Singapore 118480  
Tel: (65) 278-1650 Fax: (65)274-0296



PACO Pumps • 800 Koomey Road • Brookshire, TX 77423-8803  
(281) 934-6012 or (800) 955-5847  
Fax: (281) 934-6090 or (800) 945-4777

Represented By: